

Our associates will ensure the tool works properly before you leave the store. If you experience issues with the tool while completing your project, simply bring it back to the Tool Rental Center to get a replacement. If you purchase Damage Protection at the time of your rental, you are not responsible for repair costs for tools that break due to normal use.





See
initial start-up
instructions on page one

**COMMERCIAL
PRODUCTS™**

Iron & Oak 20 and 30 Ton Horizontal Log Splitter

Model BHH2003 and **BHH3003**

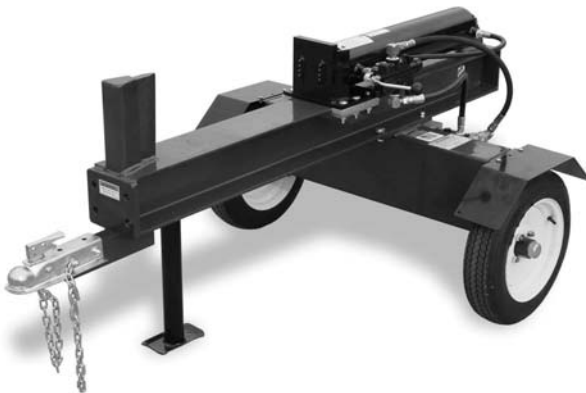

Owner / Operator and Safety Manual

 **Made in U. S. A.**

Initial Start-up Instructions

- Read all assembly, operating, and safety instructions.
- Complete and return the warranty card to register your log splitter.
- Write the serial number and date-of-purchase in this manual.
- Assemble the log splitter.
- Make sure the oil filter is properly installed. (See “Assembly Procedure” section).
- Fill the hydraulic tank with the recommended type and quantity of oil. (See “Start-Up Procedure” section).
- Fill the engine crankcase with the manufacturer’s recommended type and quantity of oil. (See “Start-Up Procedure” section).
- Fill the engine fuel tank with fresh, clean, **lead-free** gasoline. (Do not mix oil with gasoline).
- Bleed the air out of the cylinder before starting the log splitter. (See “Start-Up Procedure” section).
- Make sure the trailer hitch of the towing vehicle is equipped with a 2 inch ball.

NOTE: Iron and Oak Commercial Products reserves the right to make technical changes for product improvement. This manual may contain illustrations and photographs, for demonstration purposes, which slightly deviate from the actual product design.

Serial Number _____

Date-of-Purchase _____

Please enter the serial number and purchase date of your log splitter in the space provided. Keep this manual for future reference.

IRON & OAK

BRAVE
PRODUCTS, INC.
Streator, IL

SERIAL No.

Made in U.S.A.

Contents

Introduction	4
Safety	4
Personal Protection	4
Worksite Safety	5
Operating Safety	5
Log Splitting Safety	6
Maintenance and Repair	6
Towing	7
Refueling	8
Preventing Fires	8
Start-Up Procedure	16
Towing	18
Operation	20
Inspection and Maintenance	24
General Maintenance Check (before operating)	24
Engine Service	24
Storage	24
Hydraulic Oil Change	26
Specifications	28
Mechanical Specifications	28
Hydraulic Specifications	28
Replacement Filters	28
Hydraulic Oil Specifications (non-foaming)	28
Troubleshooting	29
Decals	30

WARNING



To avoid personal injury or death, carefully read and understand all instructions pertaining to the Iron & Oak Commercial Products' log splitter.

Do not attempt to assemble, operate, or maintain our product without fully understanding all our instructions and safety precautions. Do not operate the log splitter unless you read and understand the instructions and warnings in this manual. If any doubt or question arises about the correct or safe method of performing anything found in this or other Iron & Oak Commercial Products' manuals, contact your Iron & Oak Commercial Products' dealer or call the Sales and Service representatives at our main headquarters. Proper care is your responsibility.

WARNING

Accidents can often be avoided by being alert and recognizing potentially hazardous situations. Any individuals operating, maintaining, or repairing products manufactured by Iron & Oak Commercial Products should have the necessary training, skills, and tools required to perform these functions properly and safely. The safety information in this manual serves as a basic guide in an attempt to prevent injury or death.

Iron & Oak Commercial Products cannot anticipate every possible circumstance that might involve a potential hazard. The warnings in this manual and on the product itself are, therefore, not all-inclusive. If tools, procedures, work methods, or operating techniques that are not specifically mentioned by Iron & Oak Commercial Products are used, you must satisfy yourself that they are safe for you and for others. Make sure the log splitter will not be damaged or made unsafe by any operation, lubrication, maintenance, or repair procedures that you choose.

DO NOT proceed if any doubt arises about the correct or safe method of performing anything found in this or other Iron & Oak Commercial Products' manuals. Seek out expert assistance from a qualified person before continuing.

WARNING

CALIFORNIA PROPOSITION 65

Engine exhaust from this product contains chemicals known to the State of California to cause cancer, birth defects, or other reproductive harm.

Introduction

The commercial BHH2003 and BHH3003 Horizontal Log Splitters are designed for tough applications. With 20 or 30 tons of splitting force, a 12 second cycle time, and a 6.5 or 11 HP engine, the BHH2003 or BHH3003 will handle most of your commercial log splitting needs. An attractive, powder-coated finish provides the finest protection available, and Iron & Oak's rigid quality-control and component testing help ensure years of productive, reliable service. Since 1982, the name Iron & Oak has stood for quality and reliability when it comes to log splitters and wood processing products.

Iron & Oak Commercial Products offers the finest commercial log splitter on the market today!

- ✓ Rugged, heavy-duty construction for years of exceptional service.
- ✓ Ergonomic design for use in vertical and horizontal operating positions.
- ✓ Rigid, quality-control during manufacturing ensures greater reliability.
- ✓ Factory testing of all major components and hydraulic tank.
- ✓ Powder-coated finish for the best appearance and weather protection.
- ✓ Year-round manufacturing, parts, and support.







For additional information, contact us at:

Iron & Oak Commercial Products
1705 N. Shabbona St.
Streator, Illinois 61364-1301
Phone: (800) 817-1005 (toll free)
(815) 672-8596
Fax: (815) 672-9073
E-mail: sales@logsplitters-ironoak.com
Web Site: www.ironandoaks.com







Safety

The following is a list of safety rules you must follow in order to use your log splitter safely.







Personal Protection









- ✓  To avoid personal injury or death, carefully read and understand all instructions pertaining to the log splitter, including the engine manufacturer's operating and maintenance instruction manual.
- ✓      Always wear protective gear, such as safety goggles, tight-fitting gloves without drawstrings or loose cuffs, steel-toed shoes, and a protective hearing device.
- ✓  To prevent injury, make sure all decals are attached to the log splitter and are legible at all times.

Worksite Safety





- ✓  To avoid tripping, do not leave tools, logs, or other components laying around the work area.
- ✗  NEVER operate your log splitter on slippery, wet, muddy, or icy surfaces. The location you choose should be flat, dry, and free from any tall grass, brush, or other interferences.
- ✗  NEVER operate the engine in an enclosed area. Exhaust fumes contain carbon monoxide that can be deadly when inhaled. Make sure the area is well ventilated.
- ✗  NEVER attempt to move your log splitter over hilly or uneven terrain without a tow vehicle.
- ✗  NEVER use your log splitter at night.
- ✓  ALWAYS operate your log splitter on dry, solid, level ground.
- ✓  ALWAYS block the wheels to prevent movement of the machine while in operation.

Operating Safety



- ✓  ALLOW ONLY ONE (1) PERSON TO LOAD AND OPERATE THE LOG SPLITTER.
- ✓  Allow only adults to operate the log splitter. No one under the age of 18 should be allowed to operate the log splitter.
- ✓  Always keep bystanders, including children and pets, at least twenty-five (25) feet away from the work area. Only the operator should stand near the equipment and only within the safe operating area prescribed in this manual (see the photos on safe and unsafe operating zones in the “Operation” section).
- ✓  When the ram of the log splitter is in the return mode, keep your hands off the machine — the log splitter is designed to automatically stop when the cylinder is fully retracted.
- ✓  ALWAYS disconnect the spark plug wire when the log splitter is not in operation.
- ✗  Do not allow any person to operate the log splitter until they have read and understood the safe operating instructions contained in this manual.







- X**  Do not, under any circumstances, alter your log splitter. This equipment was designed and engineered to be used in accordance with the operating instructions. Altering the equipment, or using the equipment in such a way as to circumvent its design capabilities and capacities, could result in serious or fatal injury and **WILL VOID THE WARRANTY.**
- X**  Never operate, or allow anyone else to operate, this equipment while under the influence of medication, drugs, or alcohol.
- X**  Never wear loose clothing or jewelry that may get caught or become entangled in the log splitter.
- X**  **NEVER** place hands or feet between the log and splitting wedge or between the log and ram during the forward or reverse stroke.
- X**  **DO NOT STRADDLE OR REACH ACROSS THE SPLITTING AREA WHEN OPERATING THE LOG SPLITTER.**
- X**  Do not step over your log splitter when the engine is running because you may trip or accidentally engage the ram.
- X**  **NEVER** attempt to load your log splitter while the ram is in motion.
- X**  Only use your hand to operate the control lever. **NEVER** use your foot, knee, a rope, or any other extension device.

Log Splitting Safety









- ✓  Always keep your fingers away from any cracks that open in the log during the splitting operation.
- ✓  **ALWAYS** make sure that both ends of the log you are splitting are cut as square as possible. This will prevent the log from sliding out of position while under pressure. Logs should be 24 inches or shorter in length.
- X**  **NEVER** try to split two logs on top of each other.
- X**  Never pile logs to be split in a manner that will cause you to reach across the log splitter.

Maintenance and Repair









- ✓  Follow all safety rules, because most accidents involving the operation, maintenance, or repair of products occur because the assembler/owner/operator failed to observe basic safety rules or operating instructions.
- ✓  **ALWAYS** inspect your log splitter before each use. Make sure all nuts, bolts, screws, hydraulic fittings, hose clamps, etc. are securely tightened.

- ✓  ALWAYS check the oil level in the hydraulic oil tank and engine reservoir.
- ✗  NEVER operate your log splitter when it is in need of repair or is in poor mechanical condition.
- ✗  NEVER tamper with the engine to run it at excessive speeds. The maximum engine speed is preset and is within safety limits.
- ✗  NEVER make alterations to your log splitter in any manner. Such alterations can cause the log splitter to become unsafe and WILL VOID THE WARRANTY.
- ✗  NEVER attach a rope or extension to the control lever or add width or height to the splitting wedge. Such ALTERATIONS can cause the log splitter to become UNSAFE and WILL VOID THE WARRANTY.
- ✗  ALWAYS clean the unit after each use. If possible, store the unit inside or cover it completely, if stored outside.



Towing

- ✓  ALWAYS check before towing to make certain your log splitter is correctly and securely attached to the towing vehicle. Be sure that the ball hitch you are using is the proper size for the hitch coupler on the log splitter (see "Specification" section). Be sure the safety chains are properly hooked to the vehicle, leaving enough slack for turning.
- ✓  ALWAYS allow for added length of the log splitter when turning, parking, crossing intersections, and in all driving situations.
- ✓  ALWAYS be careful when backing up. You could jackknife your log splitter if care is not taken.
- ✓  ALWAYS disconnect your log splitter from your towing vehicle before attempting to use it.
- ✗  NEVER exceed 35 mph when towing your log splitter. Obey all state and local regulations when towing on state and local roads and highways. Adjust your speed for terrain and conditions, as needed. Be extra cautious when towing over rough terrain, especially over a railroad crossing.
- ✗  NEVER tow your log splitter when there is fuel in the engine's tank.
- ✗  NEVER allow anyone to sit or ride on your log splitter.
- ✗  NEVER carry any cargo or wood on your log splitter.

Refueling

- ✓  ONLY refuel the log splitter outdoors in a clear area void of gas fumes or spilled gasoline.
- ✓  ALWAYS use an approved fuel container to carry gasoline.
- ✓  ALWAYS replace the log splitter gas cap and the fuel container cap securely.
- ✓  If gasoline is spilled, move the machine away from the area of the spill and avoid creating any source of ignition until the spilled gasoline has completely evaporated.
- ✓  Take a class B fire extinguisher with you when operating the log splitter in dry areas as a precautionary measure against possible flying sparks.
- ✓  Always store gasoline in an approved, tightly sealed container. Store the container in a cool, dry place. Do not store the container in a house or near any heating appliance.
- ✗   Do not smoke or have open flames when refueling the engine. Do not spill fuel. If fuel should spill, quickly wipe up the spill and allow the excess to evaporate before continuing. Make sure gasoline soaked rags are properly disposed of.
- ✗  DO NOT fill the gas tank while the engine is hot or running. Allow time for the engine to cool down before refueling.

Preventing Fires

- ✗  NEVER operate the log splitter near a flame or spark. Oil and gasoline are flammable and can explode.
- ✗   NEVER smoke while operating or refueling the log splitter. Gasoline, oil, and even gas fumes can explode.

Important Notice

The log splitter is equipped with an internal combustion engine and should not be used on or near any unimproved forest-covered, brush-covered, or grass-covered land unless the engine's exhaust system is equipped with a spark arrester meeting local or state laws (if any). If a spark arrester is used, it should be maintained in effective working order by the owner and/or operator.

Start-up Procedure

Important Notice

Do not start the engine. Follow all the instructions in the “Start-up Procedure” before operating the log splitter. Failure to follow this recommendation will result in engine and hydraulic pump damage.

If this log splitter is purchased without an engine, the customer assumes all liabilities that might arise from an engine that is incompatible with the design of the log splitter. Also, any unauthorized changes or modifications to the log splitter will void all warranties.

~~**IMPORTANT:** The hydraulic system oil filter for your log splitter is not factory installed. Make sure the filter is installed before attempting to fill the hydraulic tank or start the engine. (Installation instructions are also printed on the side of the filter).~~

IMPORTANT: Before starting the engine, read the engine manufacturer's operating and maintenance instruction manual. If an engine manual was not supplied with the log splitter, it is your responsibility to obtain a manual. Start by contacting the store where you purchased the log splitter. If they cannot help you, contact the engine manufacturer.

1. Fill the hydraulic tank with SAE 10W or AW 32 tractor hydraulic oil or automatic transmission fluid, such as Dexron VI, Mercon V, or equivalent. The tank is full when the oil level is approximately one inch from the top of the tank. Do not tighten the fill cap at this time.

NOTE: The total hydraulic system oil capacity for this unit is 9.5 gallons.

2. Fill the engine's crank case with the engine manufacturer's recommended oil.
3. Lubricate the surface of the slide rail with grease. This will help to prevent wear between the slide plates and the slide rail.
4. Remove the spark plug wire from the engine. This prevents the engine from starting until the hydraulic pump and cylinder are completely filled with oil. Make sure the spark plug wire is held away from the spark plug with string or other nonconductive material.

5. Push the valve control handle with one hand to the forward (extend) position (towards the splitting wedge), and pull the engine starter cord with the other hand (approximately 15 times) until the cylinder piston moves forward. (Keep everything away from the pusher plate and wedge during this step).

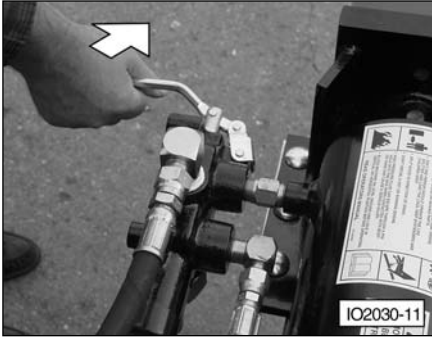

Cylinder Extend

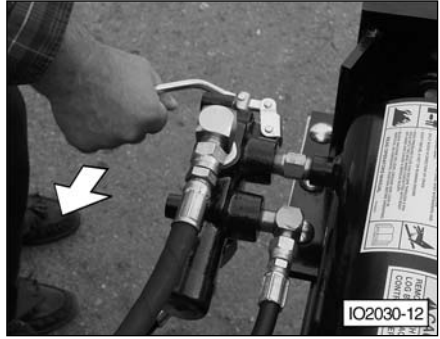

Cylinder Retract

NOTE: Extending the cylinder piston draws the hydraulic fluid through the system and expels any trapped air in the system.

6. Check the fluid level in the hydraulic tank and add oil as needed.

⚠ WARNING



Be careful not to spill fuel when filling the engine. If fuel should spill, quickly wipe off and allow the excess fuel to evaporate before continuing. Fuel and fuel vapors are highly flammable and can cause personal injury or even death when ignited.

Important Notice

If your log splitter is equipped with a factory installed engine, do not mix oil with the gasoline. Using mixed oil/gasoline in a four cycle engine can cause engine damage.

7. Fill the engine's fuel tank with fresh, clean, lead-free automotive gasoline.
8. Attach the spark plug wire and start the engine per the manufacturer's instructions.
9. With the engine running, push the valve control handle to the retract position and retract the cylinder piston. The cylinder valve will automatically stop the cylinder from retracting when it reaches the end of its stroke. Cycle the log splitter several times.
10. Again, check the fluid level in the hydraulic tank and add oil as needed. Replace and tighten the fill cap.
11. Your log splitter is now ready to use.

Towing

WARNING

Maximum Speed Limit — 35 mph

Your log splitter is built on a solid, unsuspended axle. To prevent damage or possible loss of vehicle control, use extreme caution when towing and do not exceed a vehicle speed of 35 mph, especially when driving on a bumpy road.

1. Position the hitch of the log splitter over or onto the tow vehicle's tow ball. In some cases, the hitch may not totally engage with the ball without raising the jack leg assembly. Pull the latch assembly on the hitch up and into the open position.



2. Release the latch assembly on the hitch and lock the hitch onto the ball. Attach the towing safety chains to the tow vehicle.

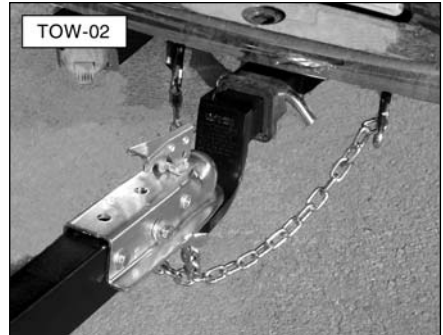

3. Raise the front leg to the towing position by pulling the spring pin. If not already secure, make sure the hitch is properly and securely attached to the ball.



4. Place a customer supplied lock or lock pin into the latch assembly of the hitch.

⚠ WARNING

Making sure the log splitter is securely attached to the vehicle is the responsibility of the owner/operator. Failure to securely attach the log splitter can cause loss of control of the vehicle or the log splitter being separated from the towing vehicle, resulting in serious injury or death.

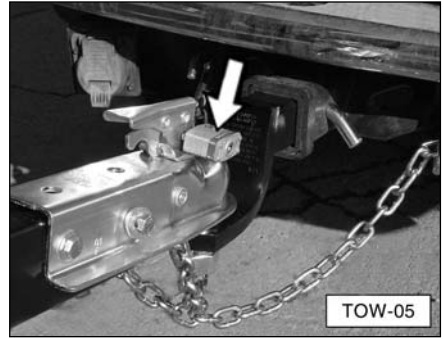

Operation

WARNING



Do not attempt to operate the log splitter without fully understanding all our instructions, safety precautions, and/or warnings. If any doubt or question arises about the correct or safe method of performing anything found in this or other Iron & Oak Products' manuals, contact your Iron & Oak Products' dealer or call the Sales and Service representatives at our main headquarters. Proper care is your responsibility.

When operating the log splitter, make sure you are standing in the **safe operating area**, as shown in these pictures. You must stay in the **safe operating area** at all times when the splitting wedge is in motion (whether extending or retracting). Never place any part of your body into a position that causes an unsafe operating condition.

1. Set your log splitter on flat, dry ground. Make sure you read all the recommendations from the "Safety" section before using the log splitter.
2. Make sure both ends of the log you are splitting are cut as square as possible. This will prevent the log from sliding out of position while under pressure. All logs should be 24 inches long or shorter.

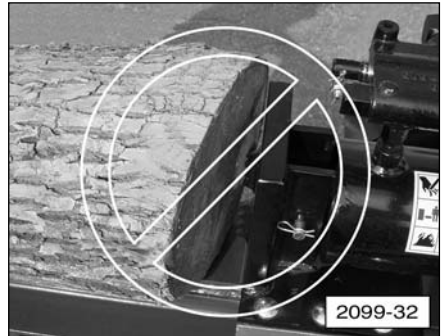

WARNING

Never attempt to split wood across the grain. The log splitter was not designed for cross-grain splitting. Doing so will damage the log splitter and may cause personal injury.

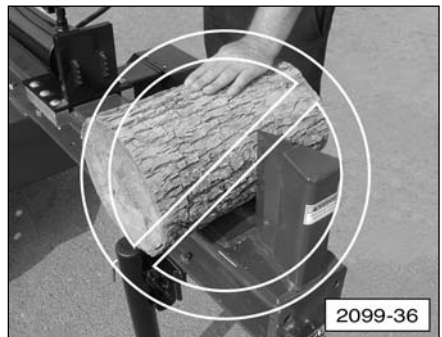

WARNING



Before loading and operating the log splitter, put on the proper protective gear such as safety goggles, face shield, hearing protection, tight-fitting gloves (without drawstrings or loose cuffs), and steel-toed shoes.

3. Start the engine using the instructions from the engine manual. If the log splitter has not been running (cold engine), warm up the engine and hydraulic system by running the engine at half throttle for three to four minutes, then advance the engine throttle control to maximum speed.
4. Use the following photos for the correct and incorrect methods of splitting logs. Never split a log using an incorrect or unsafe method.

- a. Place the log on the log splitter. Grasp the log on the sides near the middle of the block. Center the log, side-to-side, on the rail of the log splitter, making sure the sawed end is against the splitting wedge.



CAUTION



Do not place your hands on the ends of the log when loading the log splitter. This is a very **UNSAFE** method and can result in injury to your hands.

- b. Only using your hand, push the control lever forward (towards the log). If the log moves before it is contacted by the pusher plate, release the control lever and then reposition the log. Operate the log splitter only when standing in the safe operating area, as shown in the picture.



⚠ CAUTION



Make sure you stand clear from the engine's exhaust. Hot exhaust is intense and can cause serious injury.

⚠ CAUTION



If you find you must hold the log until the pusher plate touches it and holds it in place, be very careful not to put your hand between the log and the pusher plate or the log and the wedge. If you must, hold the log on top and in the middle. Remove your hand immediately when the splitting wedge engages the log. Never use extension devices to operate the valve control handle.



⚠ WARNING



Do not operate the log splitter by reaching across the rail. This is a very UNSAFE method, which can cause personal injury or even death.

⚠ WARNING



Do not reach or step across the rail while the log splitter is running. This is a very UNSAFE method, which can cause personal injury or even death.

- c. Hold the control lever, extending the splitting wedge, until the log is split or the cylinder rod stops at its maximum travel position. Stop the log splitter (forward movement) at any point in the splitting process, if you feel an unsafe log splitting condition is occurring. As the log is being split, DO NOT reach forward and attempt to catch the split wood — let it fall to the ground.

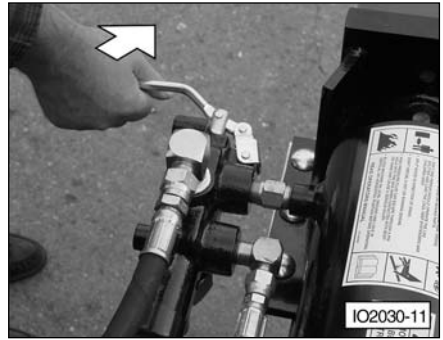

- d. Once the wedge reaches its full forward travel, pull back on the control lever to the full retract position. The ram of the cylinder will automatically retract into the cylinder. It is not necessary to hold the control lever as the cylinder retracts. Stop the wedge if the log sticks (see caution below). When the cylinder is fully retracted, the control valve will automatically shift to a neutral position.

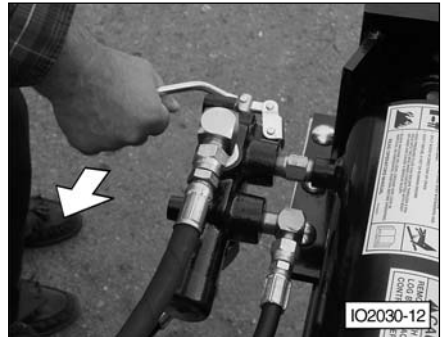

- e. DO NOT load another log or remove split pieces until the wedge has completely stopped and the control handle automatically returns to the neutral position.

⚠ CAUTION



Depending on the type of wood being split, a log may not always break into two pieces and fall to the ground. If a log sticks to the wedge, place the valve handle in the neutral position (stop the wedge from retracting) and carefully remove the log from the wedge. Allowing the log to remain attached to the wedge when it is fully retracted could lead to possible injury and/or damage to the log splitter.

Inspection and Maintenance

General Maintenance Check (before operating)

The hydraulic system (hoses, cylinder, and pump) should be carefully inspected before each use. Also, inspect the mechanical parts at the same time. Make sure all clamps, nuts, bolts, fittings, etc. are properly installed and tightened.

WARNING



Do not check for leaks with your hand. Leaks can be located by passing a piece of cardboard or wood around the suspected leak and looking for discoloration. High-pressure fluid escaping from a very small hole can be almost invisible. Escaping fluid under pressure can have sufficient force to penetrate skin, causing serious injury or even death. If fluid is injected into your skin, it must be treated immediately by a doctor familiar with this type of injury.

Always replace frayed, kinked, or cracked hoses and/or other damaged hydraulic components with Iron & Oak Commercial Products authorized parts and components specified in the “Parts” section of this manual. Replacement parts from secondary suppliers (not original Iron and Oak replacement parts) can lead to product damage and/or personal injury, and will void the warranty.

CAUTION



Do not remove the cap from the hydraulic tank or reservoir while the log splitter is running. Hot oil, under pressure, could be expelled, resulting in serious injury.

Should it become necessary to loosen or remove any hydraulic fitting or line, be sure to relieve all hydraulic pressure by shutting off the engine, removing spark plug wire, and moving the valve control handle back and forth several times until no cylinder movement is visible.

Engine Service

Refer to the engine manufacturers' manual for engine maintenance and repair.

Storage

Refer to the engine manufacturers' manual for engine storage. No special procedures are required for the hydraulic system to store the log splitter.

Specifications

Mechanical Specifications

Slide Rail	6 x 6 inch reinforced, heavy-duty H-beam
Wedge	9", High carbon steel, compound angle
Force/Tonnage	20 tons ¹ or 30 tons ²
Cylinder Stroke	24 inches
Log Opening	27 inch maximum
Cycle Time	12 seconds (approx.)
Operating Position	Horizontal
Wheels & Tires	High-Speed, 4.80 x 12"
Safety Chains	Standard
2" Hitch Coupler	Standard
Engine	6.5 HP horizontal shaft Briggs & Stratton, 6 HP Robin, 5.5 HP Honda GX ¹ , or 11 HP Briggs & Stratton, 9 HP Robin, 9 HP Honda GX ²

Hydraulic Specifications

Cylinder (Clevis-Type)	4 x 24 inch ¹ or 5 x 24 inch ² with 1-3/4 inch ¹ or 2 inch ² rod
Hydraulic Tank Capacity	7.5 gallons
Hydraulic System Capacity (includes cylinder, tank, hoses, and filter)	9.5 gallons
Hydraulic Oil Filter	Spin-on, 60 micron filter
Safety Release Control Valve	Detent, auto return
Gear Pump	2-stage, 11 GPM ¹ or 16 GPM ²

¹ Model BHH2003 only.

² Model BHH3003 only.

Replacement Filters

Replacement Filters	NAPA 1553
	FRAM PF1654
	WIX 51552

Hydraulic Oil Specifications (non-foaming)

Tractor Hydraulic Oil

For extremely cold weather conditions SAE 10W or AW 32

For extremely warm weather conditions SAE 30W or AW 68

Automatic Transmission Fluid

For all weather conditions Dexron VI, Mercon V or equivalent

Important Notice

DO NOT mix tractor hydraulic oil with automatic transmission fluid.

Also, DO NOT mix different types of hydraulic oils and transmission fluids (e.g., synthetic with non-synthetic). Hydraulic oil is NOT compatible with transmission fluid, and different TYPES of hydraulic oils and transmission fluids MAY NOT BE compatible with each other.

Troubleshooting

The following section details procedures for checking your log splitter, should you encounter a malfunction. We recommend that you do not attempt to make repairs to the log splitter. In the long run, it is better to take your log splitter to a servicing lawn and garden dealer for repairs.

Problem: When the control handle is pushed forward (extend), the splitting pusher plate does not move.

1. Check the hydraulic tank to make sure the oil level is one inch from the top of the tank.
2. Remove the pump from the engine flange. Check the coupler, making sure the drive keys are in place and there is no damage to the blue urethane spider.
3. Disconnect the pusher plate from the cylinder. Grasp the hydraulic cylinder shaft and try to pull it out. If the rod comes out easily, you will need to rebuild or replace the cylinder.
4. Once you have determined that the engine-to-pump coupler is intact and the cylinder is in good condition, you will need to replace the pump.

Problem: The engine stalls when the pusher plate engages the wood.

1. The engine may not be properly adjusted. Take the engine to a service center for repair and/or adjustment.
2. If all engine settings are correct, replace the pump.

Problem: The pusher plate moves slowly, but will split wood.

1. Check the oil level in the hydraulic tank and fill if necessary.
2. Check the high-pressure hose, fittings, and valve openings for dirt and debris that may have obstructed the openings.
3. If the ram speed is still slow, replace the pump.

Problem: The ram will not automatically retract.

1. Check the slide rail or pusher plate for damage.
2. Push the valve handle to the retract position. If the handle will not stay in this position, adjust valve detent, as described below.

Detent Adjustment Procedure

- a. Locate adjustment screw on lower side of valve body.
 - b. Loosen locknuts.
 - c. Turn adjustment screw clockwise one-half turn and retighten locknuts.
 - d. Start the engine and test for detent operation. If detent does not work, repeat Steps b and c.
3. If adjustment of detent does not correct the problem, replace the valve assembly.

Problem: Oil squirts from the fill plug during operation.

1. The oil tank may be over-filled. Drain oil to 1 inch below the top of the tank.
2. The log splitter is not level. Make sure the log splitter is on level ground.

Decals

WARNING



Make sure all decals are attached to the log splitter and/or engine and are legible at all times.

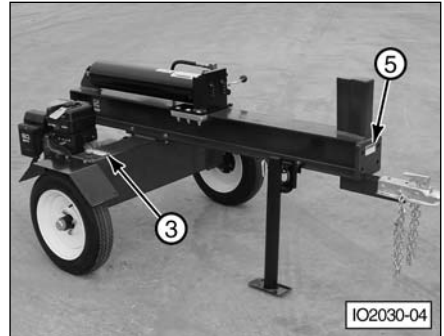
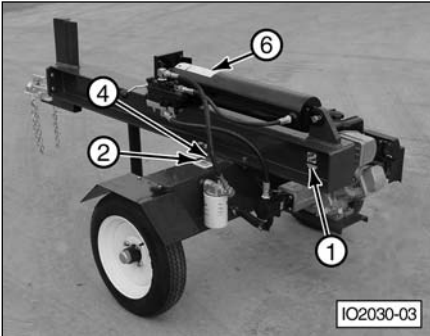

(2)

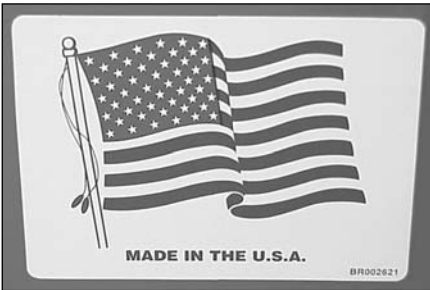

(3)



(4)

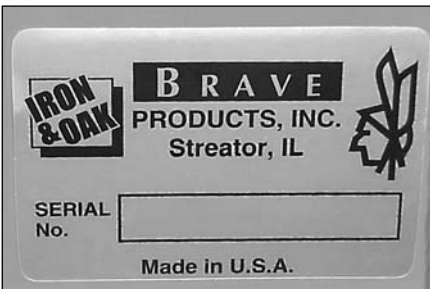

(5)



(6)

WARNING



Read safety instructions before operating this equipment. Failure to do so may result in crush and/or amputation injuries from moving parts.

SAFETY INSTRUCTIONS

- Operate log splitter on flat, dry ground.
- Lock rail into Vertical or Horizontal position before using. (Some Iron & Oak models operate only in Horizontal position.)
- NO ONE under age 18 is allowed to operate log splitter.
- Keep bystanders, children, and helpers at least 25 ft. away.
- Wear safety glasses, tight fitting work gloves, and safety shoes.
- Keep hands and all body parts away from splitting wedge, base plate, partially split wood, and moving parts.
- Lift logs by the sides, not the ends.
- Only one person is permitted to stabilize logs and operate the controls.
- Do not check for oil leaks with your hand. Use a cloth. High pressure hydraulic fluid can penetrate your skin, causing blood poisoning.
- Never operate log splitter under the influence of alcohol or drugs.



WARNING

Only load log splitter by holding logs by their sides. Failure to do so may result in crush or amputation

WARNING



Read and understand operator's manual before using this machine. Failure to follow instructions could result in serious injury.

OPERATING INSTRUCTIONS

1. Read Owner/Operator manual for complete instructions.
2. Start engine using instructions from engine manual. Advance throttle control to maximum speed.
3. Lift log by sides and place onto rail, against base plate or wedge.
4. If necessary, stabilize log by holding the top, never the end.
5. Move control handle to FORWARD position to extend cylinder.
6. Release handle to STOP the cylinder.
7. Move control handle to REVERSE position to retract cylinder. Cylinder will retract automatically.

CONTROL VALVE

Reverse

↑ Neutral ↓

Forward

Item	Part No.	Description	Qty.
1 (NS)	BR002499	Decal, Iron & Oak	2
2	BR002621	Decal, Flag	1
3	BR002652	Decal, Notice	1
4	BR002521	Decal, Serial Number	1
5	BR002653	Decal, Maximum Speed	1
6	BR002308	Decal Kit, Standard Models	1

NS - Not Shown